

# 2.4

## Universal Terminal Boxes

Ex-e/Ex-i Technology

2 Light alloy metal design for Zone 1, 2, 21 and 22

### Connecting your field devices

The new sturdy CEAG terminal boxes made of a light alloy metal are used to distribute and conduct electricity in hazardous explosive areas of the Zones 1, 2, 21 and 22. Optionally, all of the modular terminals up to 35 mm<sup>2</sup> pursuant to EN 60079-7 are available in these terminal boxes.

Variable equipment with various cable and line ducts pursuant to customer specification can be realised with the terminal boxes made of light alloy metal.

Drilled holes, cable and line ducts, through which no lines are conducted, should be closed with certified threaded stoppers.

High chemical resistance of the housing is ensured by the use of impact-resistant plastic powder coating.

### Corrosion resistant

Covered screws and all outside and inside metallic parts are made of stainless steel.

The terminal boxes made of light metal have an outside earthing connection.



### Features

- Mechanical, chemical and thermal resistance
- Plastic powder coating
- Can be equipped individually, Impact-resistant

To make the choice of the right terminal boxes or branching boxes for your application, the tables on this page contain the basic data. You can use these tables to identify and configure your terminal boxes.

The table "Max. number of terminals" is based on the mechanical conditions of the terminal enclosure such as length of mounting rail and height the terminals. It is based on common terminal types such as

Phoenix® or Wago®. The permissible number of terminals in terms of the type examination certificate must be checked in each individual case based on the current load tables in the operating instructions.

On the basis of the maximum drilled and the faulty circuit diameter of the cable and line duct, you can select the relevant terminal box by means of the number of ducts that you need.

**Maximum number of terminals**

Type	Terminal cross-section in mm <sup>2</sup>						
	2.5	4	6	10	16	25	35
GHG 793 0101	6	5	4	–	–	–	–
GHG 723 0001	33	27	20	16	15	–	–
GHG 723 1001	88	72	54	44	40	15	15
GHG 723 2001	136	112	84	68	60	22	22

**Terminal rail**

Type	Rail length
GHG 793 0101	46 mm
GHG 723 0001	185 mm
GHG 723 1001	2 x 242 mm
GHG 723 2001	2 x 362 mm



**Dimensions**

Type	Width	x	Length	x	Height
GHG 793 0101	130 mm	x	82 mm	x	72 mm
GHG 723 0001	220 mm	x	120 mm	x	81 mm
GHG 723 1001	280 mm	x	230 mm	x	111 mm
GHG 723 2001	400 mm	x	230 mm	x	111 mm

**Space required for wire and cable entries**

Type	Interference Plastic	Diameter Metal
M12	Ø 19 mm	Ø 21 mm
M16	Ø 25 mm	Ø 21 mm
M20	Ø 31 mm	Ø 26,5 mm
M25	Ø 37 mm	Ø 33 mm
M32	Ø 46 mm	Ø 45,1 mm
M40	Ø 56 mm	Ø 53 mm
M50	Ø 68 mm	Ø 60,5 mm
M63	Ø 84 mm	Ø 80 mm

**max. drilled surface**

Type	Width	x	Height
GHG 793 0101	80 mm	x	45 mm
GHG 723 0001	180 mm	x	53 mm
GHG 723 1001	232 mm	x	83 mm
GHG 723 2001	352 mm	x	80 mm

## GHG793 Ex-e/Ex-i terminal box



GHG 793 0101 R0003

### Technical data

#### Type 793 01 up to 11 terminals

Marking accd. to 2014/34/EU	⊕ II 2 G Ex dem ia II, IIC T6 / ⊕ II 2 D tD A21 IP66 T80 °C						
Permissible ambient temperature	-20 °C to +40 °C -55 °C to +55 °C (option)						
EC-Type Examination Certificate	PTB 00 ATEX 3108						
Rated voltage	up to 690 V						
Rated current	depends on terminal mounting						
Degree of protection accd. to EN 60529	IP66						
Enclosure material	light alloy die-casting (AlSi)						
Enclosure colour	light grey						
Terminal cross section	up to 6 mm <sup>2</sup>						
Weight	approx. 0.68 kg						
Drillings/cable glands	M16	M20	M25	M32	M40	M50	M63
Max. number down	5	2	2	1	-	-	-
Max. number of terminals acc. to certification	2.5 mm <sup>2</sup> 16	4 mm <sup>2</sup> 14	6 mm <sup>2</sup> 10				

### Ordering details

Content	Cable gland	No. of terminals	Order No.
<b>Type 793 01 up to 11 terminals with screw terminals 2 x 2.5 mm<sup>2</sup> + PE-terminals 2 x 4 mm<sup>2</sup></b>			
Ex-e	without drilling	1 x Ex-e*/1 x PE	GHG 793 0101 R0003

\* according to type examination certificate individual extensible

### Dimension drawing

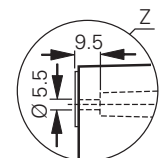
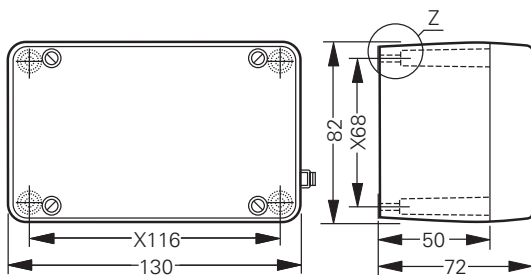

Type 793 01

X = fixing dimensions

Dimensions in mm

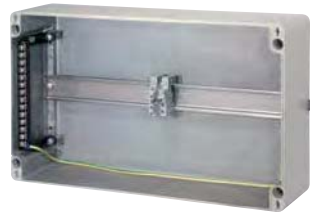

GHG 723 2001 R0002



GHG 723 1001 R0002



GHG 723 0001 R0002

Technical data

Type 723 00 | 723 10 | 723 20 up to 96 terminals

Marking accd. to 2014/34/EU	⊕ II 2 G Ex e IIC T4/T5/T6 Gb / ⊕ II 2 D Ex ctb IIIC T80 °C/T95 °C Db
Permissible ambient temperature	-20 °C to +40 °C -55 °C to +55 °C (option)
EC-Type Examination Certificate	BVS 13 ATEX E013X
IECEX Certificate of Conformity	IECEX BVS 13.0031X
Marking accd. to IECEx	Ex e IIC T4/T5/T6 Gb Ex tb IIIC T80 °C/T95 °C Db IP6X
Rated voltage	up to 690 V
Rated current	depends on terminal mounting
Degree of protection accd. to EN 60529	IP66
Enclosure material	light alloy die-casting (AlSi)
Enclosure colour	light grey

Type 723 00 up to 24 terminals

Terminal cross section	max. 35 mm <sup>2</sup>						
Weight	approx. 1.41 kg						
Drillings/cable glands	M16	M20	M25	M32	M40	M50	
Max. number down	8	4	3	–	–	–	
Dimensions (L x W x H)	220 x 80 x 120 mm						
Terminal mounting space on the terminal rail	1 x 185 mm						
Max. number of terminals acc. to certification	2.5 mm <sup>2</sup> 15	4 mm <sup>2</sup> 17	6 mm <sup>2</sup> 18	10 mm <sup>2</sup> 18	16 mm <sup>2</sup> 14	25 mm <sup>2</sup> –	35 mm <sup>2</sup> –

Type 723 10 up to 82 terminals

Terminal cross section	max. 50 mm <sup>2</sup>						
Weight	approx. 3.84 kg						
Drillings/cable glands	M16	M20	M25	M32	M40	M50	
Max. number down	22	10	7	4	3	2	
Dimensions (L x W x H)	220 x 111 x 230 mm						
Terminal mounting space on the terminal rail	2 x 242 mm						
Max. number of terminals acc. to certification	2.5 mm <sup>2</sup> 2 x 41	4 mm <sup>2</sup> 2 x 34	6 mm <sup>2</sup> 2 x 26	10 mm <sup>2</sup> 2 x 20	16 mm <sup>2</sup> 1 x 17	25 mm <sup>2</sup> 1 x 17	35 mm <sup>2</sup> 1 x 14

Type 723 20 up to 96 terminals

Terminal cross section	max. 95 mm <sup>2</sup>						
Weight	approx. 4.87 kg						
Drillings/cable glands	M16	M20	M25	M32	M40	M50	
Max. number down	30	18	10	6	5	4	
Dimensions (L x W x H)	400 x 111 x 230 mm						
Terminal mounting space on the terminal rail	3 x 362 mm						
Max. number of terminals acc. to certification	2.5 mm <sup>2</sup> 2 x 48	4 mm <sup>2</sup> 2 x 48	6 mm <sup>2</sup> 2 x 36	10 mm <sup>2</sup> 2 x 36	16 mm <sup>2</sup> 1 x 28	25 mm <sup>2</sup> 1 x 23	35 mm <sup>2</sup> 1 x 22

## GHG723 Ex-e/Ex-i terminal box



GHG 723 0001 R0002



GHG 723 1001 R0002

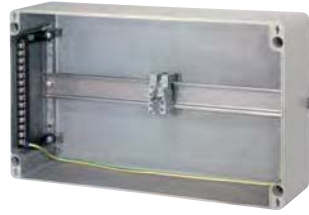

GHG 723 2001 R0002

### Ordering details

Content	Cable gland	No. of terminals	Order No.
<b>Type 723 00 assembled with screw terminals 2 x 2.5 mm<sup>2</sup> + PE-terminals 4 mm<sup>2</sup></b>			
Ex-e	without drilling	1 x Ex-e <sup>1)</sup> /1 x PE	<b>GHG 723 0001 R0002</b>
<b>Type 723 10 assembled with screw terminals 2 x 2.5 mm<sup>2</sup> + PE-terminals 4 mm<sup>2</sup></b>			
Ex-e	without drilling	1 x Ex-e <sup>1)</sup> /14 x PE	<b>GHG 723 1001 R0002</b>
<b>Type 723 20 assembled with screw terminals 2 x 2.5 mm<sup>2</sup> + PE-terminals 4 mm<sup>2</sup></b>			
Ex-e	without drilling	1 x Ex-e <sup>1)</sup> /14 x PE	<b>GHG 723 2001 R0002</b>

<sup>1)</sup> according to type examination certificate individual extensible

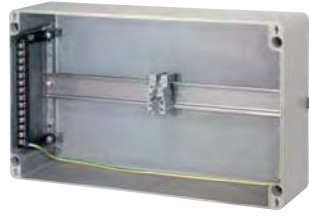

GHG 723 2001 R0002



GHG 723 1001 R0002



GHG 723 0001 R0002

Dimension drawing

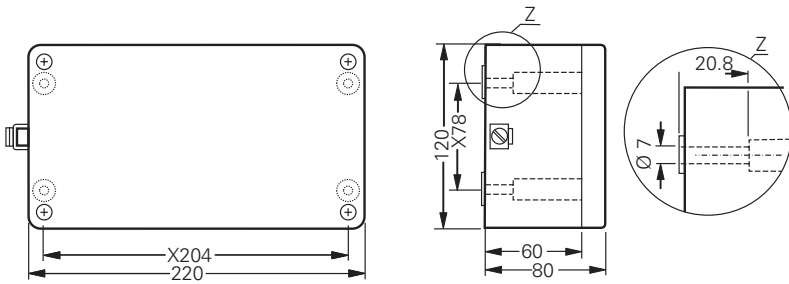

Type 723 00

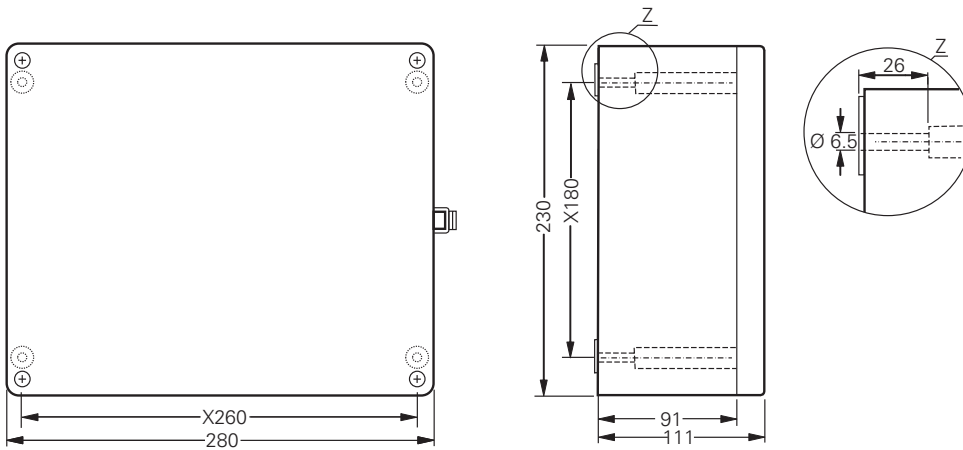

Type 723 10

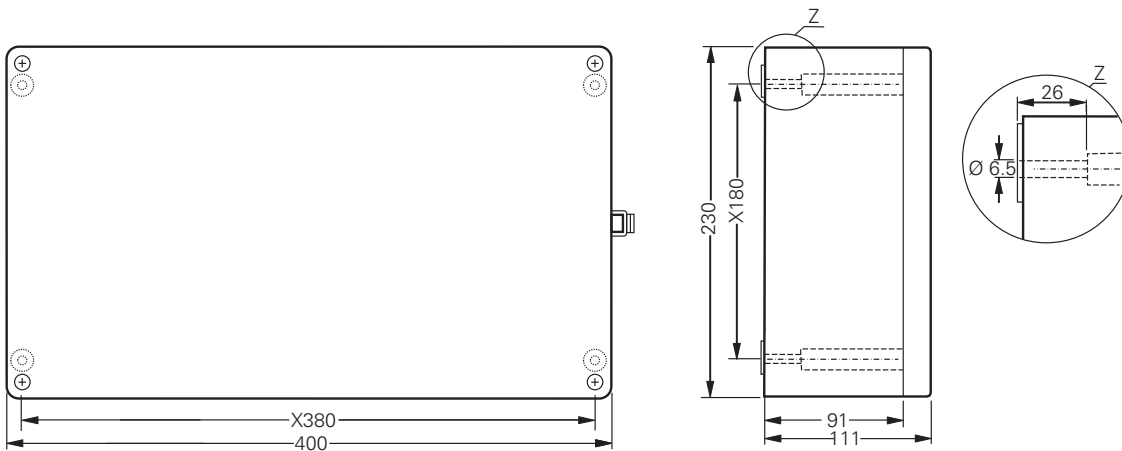

Type 723 20

X = fixing dimensions